

# Pro-V™ Multivariable Flowmeter

## Model M22 Inline Vortex

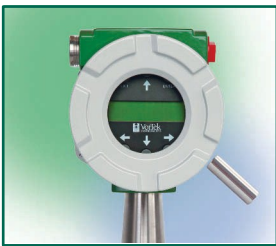

VorTek Instruments Pro-V™ M22 Multivariable Vortex Flowmeter offers accurate and reliable flow metering in a multivariable design. The multivariable design incorporates a high-accuracy velocity sensor, a precision platinum RTD temperature sensor, and a solid-state pressure transducer. The M22 can deliver volumetric flow, mass flow, temperature, pressure, density, and energy (BTU) measurements from a single installed device.

This drastically reduces complexity, equipment costs, and installation costs in comparison to installing multiple stand-alone instruments to arrive at the same process measurements.

The M22 flowmeter offers an industry-leading variety of communication and power options. In addition to providing traditional communication methods such as analog output signals, the flowmeter also offers the latest and most advanced serial communication options such as BACnet®/IP and Modbus® TCP/IP. The M22 is the only vortex flowmeter on the market to provide Power over Ethernet (PoE) capabilities. Power over Ethernet functionality delivers power and data through a single ethernet cable. Both simplifying installation and reducing installation costs.

### Pro-V™ Advantage:

- Volumetric or mass flow monitoring of most liquids, gases, and steam
- Multivariable design delivers volumetric flow, mass flow, temperature, pressure, density, and energy (BTU) measurements from a single installed device
- Mass flow equations-real gas, ideal gas, AGA 8, API 2540
- Compensated mass flow reading of liquids, gases, and steam
- Energy (BTU) Monitoring—ability to compute and output energy use
- Reduced bore option to capture low flow conditions
- Reliable—no moving parts, no fluid to sensor contact
- High accuracy with rangeability up to 100:1
- Temperatures up to 750°F
- Pressures up to 1500 psig
- Remote electronics option available for use in harsh environments or locations with limited access
- Two-wire loop-powered design saves on energy costs
- HART protocol communications-Standard
- Advanced serial communication options: BACnet®/IP, Modbus® TCP/IP, BACnet® MS/TP, and Modbus® RTU
- Power over Ethernet (PoE) functionality delivers power and data through a single Ethernet cable
- FM, FMC, ATEX, IECEx Approved



**VorTek**  
INSTRUMENTS

VorTek Instruments, LLC

8475 West I-25 Frontage Rd., Suite 300  
Longmont, CO 80504 USA

Tel: 303/682-9999 Fax: 303/682-4368  
info@vortekinst.com

## Pro-V™ Principle of Operation

Vortex flowmeters measure flows of liquid, gas and steam by detecting the frequency at which vortices are alternately shed from a bluff body. According to proven laws of physics, the frequency at which the vortices are alternately shed is directly proportional to the flow velocity.

As flow passes a bluff body in the flow stream, the vortices create low and high pressure zones behind the bluff body, or shedder bar. The Pro-V™ M22 uses a piezoelectric crystal sensor to detect the pressure exerted by the vortices on the velocity sensor. The piezoelectric converts these “pulses” into electrical signals. The meter uses an all welded sensor design to create a robust sensor and to minimize potential leakages.

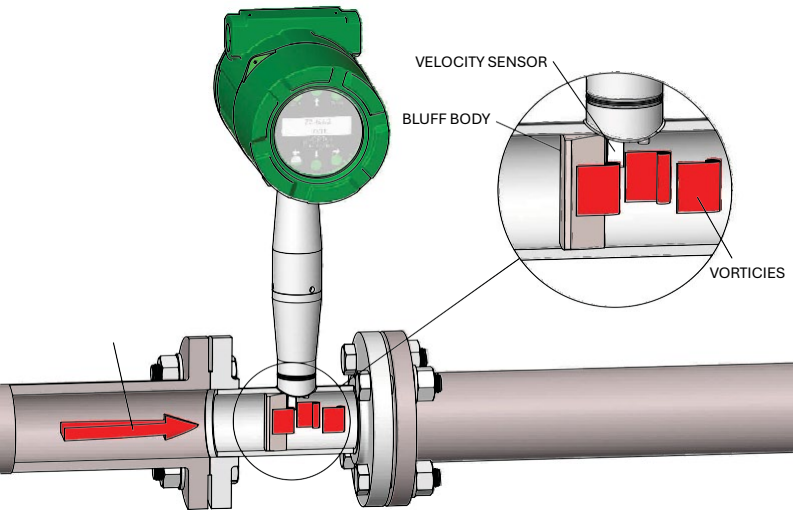

### Pro-V™ Model M22-VTP

The Model M22-VTP offers you flow computer functionality in a compact field device. This multivariable instrument incorporates temperature and pressure sensors to provide an instantaneous reading of the compensated mass flow rate of gases, liquids and steam. In addition to outputs for totalized mass and alarm settings, the field-configurable electronics deliver up to three analog 4-20 mA outputs of five process measurements, including volumetric flow rate, mass flow rate, pressure, temperature and density.

### Pro-V™ Model M22-VT

The Model M22-VT integrates a precision 1000 Ohm platinum RTD temperature sensor that can be used to calculate and output a compensated mass reading. This device is typically used to measure flow rates of saturated steam.

### Pro-V™ Model M22-V

The Model M22-V delivers a direct reading of volumetric flow rate—generally the most cost-effective solution for liquid flow monitoring—in applications ranging from general water flows to hydrocarbon fuel flow measurement.

### Pro-V™ Model M22-EM

The Model M22 Energy Monitoring option permits real-time calculation of energy consumption for a facility or process. The meter can be programmed to measure steam, hot water or chilled water. The Model M22-VTP flowmeter monitors one side of the process, either sent or returned, and uses the input from a second separate temperature sensor on the opposite leg of the process to calculate the change in energy. Selectable energy units include BTU, joules, calories, Watt-hours, Megawatt-hours and Horsepower-hours. The local or remote electronics indicate two temperatures, delta T, mass total and energy total.

### Pro-V™ Model M22-VTEP, VETEP

Similar to M22-VTP but with the option for an external input (T or P) via RTD or 4-20mA or one of each.

## Performance Specifications

### Accuracy

Mass flow rate for gas and steam based on 50-100% of pressure range.

Model M22 Multiparameter Inline Vortex Meter		
Process Variables	Liquids	Gas & Steam
Volumetric Flow Rate	± .7% of Rate	± 1% of Rate
Mass Flow Rate	± 1% of Rate	± 1.5% of Rate
Temperature	± 2°F (± 1°C)	± 2°F (± 1°C)
Pressure	± .3% of Full Scale	± .3% of Full Scale
Density	± .3% of Reading	± .5% of Reading

### Repeatability

Mass Flow Rate..... ± .2% of rate  
 Volumetric Flow Rate..... ± .1% of rate  
 Temperature..... ± .2°F (± .1°C)  
 Pressure..... ± .05% of full scale  
 Density..... ± .1% of reading

### Stability Over 12 Months

Mass Flow Rate..... ± .2% of rate  
 Volumetric Flow Rate..... ± negligible  
 Temperature..... ± .9°F (± .5°C)  
 Pressure..... ± .1% of full scale  
 Density..... ± .1% of reading

### Response Time

Adjustable from 1 to 100 seconds.

## Operating Specifications

Any gas, liquid, or steam compatible with 316L stainless steel, C276 hastelloy, or A105 carbon steel. Not recommended for multi-phase fluids.

### Process and Ambient Temperature

Process Standard Temperature (code ST): -330 to 500°F (-200 to 260°C)  
 Process High Temperature (code HT): to 750°F (400°C)  
 Ambient Operating: -40 to 140°F (-40 to 60°C)  
 Ambient Storage: -40 to 185°F (-40 to 85°C)

Pressure Transducer Ratings			
Full Scale Operating Pressure		Max. Over-Range Pressure	
psia	bara	psia	bara
30	2	60	4
100	7	200	14
300	20	600	40
500	35	1000	70
1000	69	2000	138
1500	100	2750	175
2500	172	5000	344

### Power Requirements

DCL option: 12-36 VDC, 25mA, 1W max, loop powered (single output)  
 DCH option: 12-36 VDC, 300mA, 9W max, (multiple outputs)  
 DCHPOE option: 12-28 VDC or Power over Ethernet, 5W maximum (multiple outputs)  
 AC option: 100-240 VAC, 50/60Hz line power, 5W (multiple outputs)

### Display

Alphanumeric 2 line x 16 character LCD digital display Six pushbuttons for full field

configuration. Pushbuttons can be operated with magnetic wand without removal of enclosure covers. Display can be mounted in 90° intervals for better viewing.

**Output Signals**

- Analog: 4-20 mA
- Alarm: Solid state relay, 40 VDC
- Totalizer Pulse: 50 millisecond pulse, 40 VDC
- Volumetric or Loop Powered Mass: One analog, one totalizer pulse, HART
- Multivariable option: Up to three analog signals, three alarms, one totalizer pulse, HART, Modbus or BACnet process monitoring

**Physical Specifications**

**Wetted Materials**

- Standard 316L Stainless Steel, plus
  - Optional Carbon Steel or Hastelloy C
  - DuPont Teflon® based thread sealant on models with pressure transducer

**Approvals**

- FM, FMC CLASS I, DIV. 1, GROUPS B,C,D  
CLASS II/III, DIV. 1, GROUPS E,F,G  
Type 4X and IP66, T6, Ta = -40 to 60°C  
CSA C22.2
- KOSHA Korea KC Ex Certification
- ATEX II 2 G Ex d IIB + H2 T6  
II 2 D EX tD A21 IP66 T85°C, Ta = -40 to 60°C
- IECEX Ex d IIB + H2 T6  
Ex tD A21 IP66 T85°C, Ta = -40 to 60°C
- CRN CSA B51 – Boiler and Pressure Vessel



**Sizing Considerations**

Piping Conditions	Pipe Diameters, D	
	Upstream	Downstream
One 90° elbow before meter	10D	5D
Two 90° elbows before meter	15D	5D
Two 90° elbows before meter, out of plane	30D	10D
Reduction before meter	10D	5D
Expansion before meter	20D	5D
Partially open valve	30D	10D

**Velocity Range**

- Maximum velocity, liquid: 30 feet/sec (9 meters/second)
- Minimum velocity, liquid: 1 foot/sec (.3 meters/second)
- Maximum velocity, gas or steam: See Table Below
- Minimum velocity, gas or steam feet/sec (meters/second):

$$\frac{5}{\sqrt{\text{density (lb/ft}^3)}} \quad \frac{6.1}{\sqrt{\text{density (kg/m}^3)}}$$

**Pressure Drop Equations**

$\Delta P = 0.00024\rho V^2$  English Units ( $\Delta P$  in psi,  $\rho$  in lb/ft<sup>3</sup>, V in ft/sec)  
 $\Delta P = 0.00011\rho V^2$  Metric Units ( $\Delta P$  in bar,  $\rho$  in kg/m<sup>3</sup>, V in m/sec)

Consult the VorTek Instruments Sizing Program at <https://vortek.sizingapp.com> for easy calculation of flow range.

Water Minimum and Maximum Flow Rates											
Rate	Nominal Pipe Size (in)										
	0.5	0.75	1	1.5	2	3	4	6	8	10	12
GPM min	0.9	1.4	2.2	5.5	9.2	21	36	81	142	224	317
GPM max	22	40	67	166	276	618	1076	2437	4270	6715	9501
Nominal Pipe Size (mm)											
	15	20	25	40	50	80	100	150	200	250	300
M <sup>3</sup> /hr min	0.2	0.3	0.5	1.3	2.1	4.7	8.1	18	32	51	72
M <sup>3</sup> /hr Max	5	9	15	38	63	140	244	554	970	1525	2158

Gas or Steam Max Velocity											
Rate	Nominal Pipe Size (in)										
	0.5	0.75	1	1.5	2	3	4	6	8	10	12
FT/SEC Max	175	250	250	300	300	300	300	300	300	300	300
Nominal Pipe Size (mm)											
	15	20	25	40	50	80	100	150	200	250	300
M/SEC Max	53	76	76	90	90	90	90	90	90	90	90

**Product Disposal Information**

To ensure environmental safety and compliance, please follow these disposal instructions for the product and its components:

**Electronic Components:**

This product contains electronics that must be recycled through approved e-waste recycling programs. Electronics can contain harmful materials and should be prevented from entering landfills. Do not place electronics in regular trash.

**Metal Parts:**

Any metal components can be separated and recycled through your local metal recycling facility.

**Packaging Materials:**

Recycle or reuse packaging materials such as cardboard or plastics, following local recycling guidelines.

For local disposal sites, refer to:

- Call2Recycle (USA, Canada)
- Earth911 (USA, Canada)
- SERI (International)

In the USA, for more information, visit:

- EPA's battery disposal guide
- EPA's electronics recycling page

By following these guidelines, you help reduce waste and support environmental sustainability.



Typical Saturated Steam Minimum and Maximum Flow Rates (lb/hr)											
Nominal Pipe Size (in)											
Pressure	0.5	0.75	1	1.5	2	3	4	6	8	10	12
5 psig	6.5 52	12 122	20 265	49 650	82 1087	183 2431	318 4231	722 9594	1264 16806	1988 26429	2813 37395
100 psig	15 271	27 639	46 1386	112 3405	187 5690	419 12729	728 22156	1652 50233	2893 87998	4550 138386	6438 195803
200 psig	20 493	37 1163	62 2525	151 6203	253 10365	565 23184	983 40354	2229 91494	3905 160279	6141 252055	8689 356635
300 psig	24 716	45 1688	74 3664	182 9000	304 15040	680 33642	1184 58556	2685 132763	4704 232575	7397 365747	10466 517499
400 psig	28 941	51 2220	85 4816	209 11831	349 19770	780 44222	1358 76971	3079 174516	5393 305717	8481 480771	12000 680247
500 psig	31 1170	57 2760	95 5988	233 14711	389 24582	870 54987	1514 95710	3433 217001	6014 380148	9457 597812	13381 845850

Typical Saturated Steam Minimum and Maximum Flow Rates (kg/hr)											
Nominal Pipe Size (mm)											
Pressure	15	20	25	40	50	80	100	150	200	250	300
0 barg	3 18	5 42	8 91	19 224	32 375	72 838	126 1459	286 3309	500 5797	786 9116	1113 12898
5 barg	6 95	11 224	18 485	45 1192	75 1992	167 4455	290 7754	658 17581	1153 30799	1813 48434	2565 68530
10 barg	8 168	15 397	24 862	59 2118	99 3539	222 7915	387 13777	877 31237	1537 54720	2417 86053	3419 121758
15 barg	9 241	17 569	29 1236	71 3036	119 5073	266 11347	463 19750	1050 44779	1840 78444	2893 123360	4094 174543
20 barg	11 314	20 742	33 1610	81 3956	136 6611	304 14787	529 25738	1199 58355	2100 102226	3303 160761	4673 227463
30 barg	13 463	24 1092	40 2370	99 5822	165 9729	369 21763	642 37880	1455 85884	2548 150451	4007 236599	5669 334766

Typical Air Minimum and Maximum Flow Rates (SCFM) Air at Standard Process Conditions 70°F, 14.6959 PSIA											
Nominal Pipe Size (in)											
Pressure	0.5	0.75	1	1.5	2	3	4	6	8	10	12
0 psig	1.8 18	3 41	5 90	13 221	22 369	50 826	87 1437	198 3258	347 5708	546 8976	773 12701
100 psig	5 138	9 325	15 704	38 1730	63 2890	141 6466	245 11254	555 25515	972 44698	1529 70292	2163 99456
200 psig	7 258	13 609	21 1322	52 3248	86 5427	193 12140	335 21131	761 47911	1332 83931	2095 131895	2965 186752
300 psig	8 380	15 896	25 1944	63 4775	104 7978	234 17847	407 31064	922 70431	1615 123375	2540 194025	3594 274529
400 psig	10 502	18 1183	29 2568	72 6309	120 10542	269 23580	467 41043	1060 93057	1857 163000	2920 256358	4132 362724
500 psig	11 624	20 1472	33 3195	80 7849	134 13115	300 28034	521 51063	1182 115775	2071 203000	3257 318941	4608 451272

Typical Air Minimum and Maximum Flow Rates (nm <sup>3</sup> /hr) Air at Standard conditions of 20°C, 1.0133 BARA											
Nominal Pipe Size (mm)											
Pressure	15	20	25	40	50	80	100	150	200	250	300
0 barg	3 28	5 66	9 142	21 350	36 584	79 1307	138 2275	313 5157	549 9034	863 14207	1221 20102
5 barg	7 165	13 390	21 847	52 2080	87 3476	194 7775	337 13533	764 30682	1339 53749	2105 84525	2979 119596
10 barg	9 304	17 716	29 1554	70 3819	117 6381	262 14273	457 24844	1035 56329	1814 98676	2853 155178	4036 219563
15 barg	11 442	21 1044	34 2265	85 5565	142 9299	317 20801	551 36205	1250 82087	2190 143801	3444 297386	4873 319968
20 barg	13 582	24 1373	40 2979	97 7318	162 12229	363 27354	632 47612	1434 107949	2511 189105	3949 297386	5588 420775
30 barg	16 862	29 2034	48 4414	118 10843	198 18119	442 40529	770 70544	1745 159942	3057 280187	4807 440621	6801 623439

### Turndown

Turndown is application dependent. Consult the VorTek Instruments Sizing Program at <https://vortek.sizingapp.com>. Turndown can exceed 100:1.



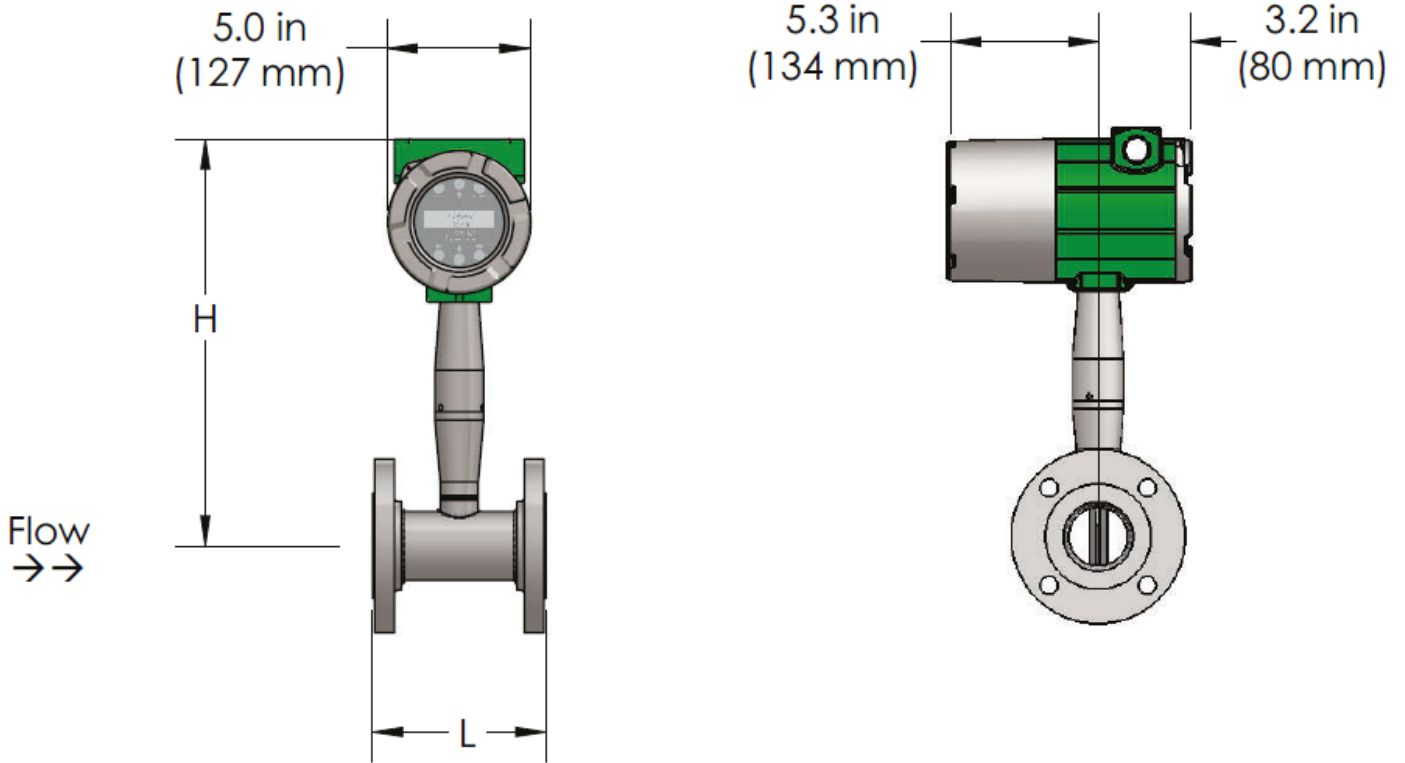

Flow Meter Nominal Size	L	H	Weight		
			ANSI 150 (PN 16)	ANSI 300 (PN 40)	ANSI 600 (PN 64)
1/2 inch (15mm)	4.56 in (116 mm)	13.5 in (343 mm)	12 Lb (5.5 kg)	12.5 Lb (5.7 kg)	13.4 Lb (6.1 kg)
3/4 inch (20 mm)	4.8 in (122 mm)	13.5 in (343 mm)	13 Lb (5.9 kg)	14.6 Lb (6.6 kg)	15.6 Lb (7.1 kg)
1 inch (25 mm)	4.94 in (126 mm)	13.5 in (343 mm)	13.4 Lb (6.1 kg)	16.3 Lb (7.4 kg)	16.4 Lb (7.5 kg)
1-1/2 inch (40 mm)	5.5 in (140 mm)	13.8 in (351 mm)	16.3 Lb (7.4 kg)	23.3 Lb (10.6 kg)	24.6 Lb (11.2 kg)
2 inch (50 mm)	6.0 in (153 mm)	14.0 in (356 mm)	21.2 Lb (9.6 kg)	26.8 Lb (12.2 kg)	33.2 Lb (15.1 kg)
3 inch (80 mm)	6.9 in (175 mm)	14.6 in (371 mm)	33 Lb (15.0 kg)	41.0 Lb (18.6 kg)	56.1 Lb (25.5 kg)
4 inch (100 mm)	8.0 in (203 mm)	15.1 in (384 mm)	45.8 Lb (20.8 kg)	66.8 Lb (30.3 kg)	96.0 L (43.6 kg)
6 inch (150 mm)	9.0 in (229 mm)	16.2 in (411 mm)	68.3 Lb (31.0 kg)	106.3 Lb (48.2 kg)	194.3 Lb (88.2 kg)
8 inch (200 mm)	10.5 in (267 mm)	17.2 in (437 mm)	112.4 Lb (51.0 kg)	168.4 Lb (76.5 kg)	299.0 Lb (136 kg)
10 inch (250 mm)	15.0 in (381 mm)	18.2 in (462 mm)	188.3 Lb (85.5 kg)	262.3 Lb (119.1 kg)	462.3 Lb (209.9 kg)
12 inch (300 mm)	17.7 in (450 mm)	19.2 in (488 mm)	298.6 Lb (135.6 kg)	402.6 Lb (182.8 kg)	606.6 Lb (275.4 kg)

Add 11 lb (5 KG) for remote electronics

**Dimensional Outline: Pro-V™ Inline Wafer Models**

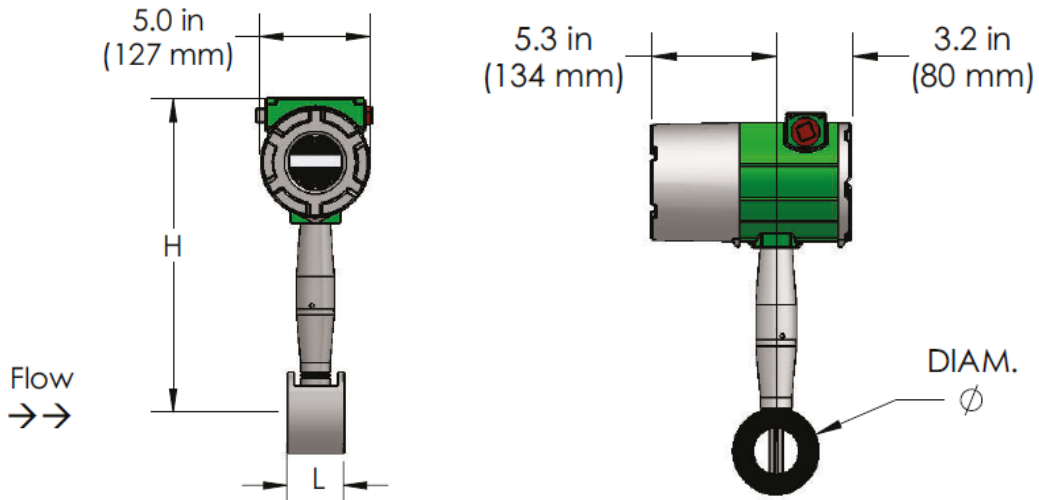

Flow Meter Nominal Size	L	H	DIAM	Weight
				Approximate Weight
1/2 inch (15mm)	4.560 in (116 mm)	13.5 in (343 mm)	1.38 in (35 mm)	9.8 Lb (4.4 kg)
3/4 inch (20 mm)	4.800 in (122 mm)	13.5 in (343 mm)	1.69 in (43 mm)	10.0 Lb (4.5 kg)
1 inch (25 mm)	2.756 in (70 mm)	13.5 in (343 mm)	2.0 in (51 mm)	10.4 Lb (4.7 kg)
1-1/2 inch (40 mm)	2.756 in (70 mm)	13.8 in (351 mm)	2.88 in (73 mm)	12.4 Lb (5.6 kg)
2 inch (50 mm)	2.956 in (75 mm)	14.0 in (356 mm)	3.62 in (92 mm)	14.9 Lb (16.8 kg)
3 inch (80 mm)	3.947 in (100 mm)	14.6 in (371 mm)	5.00 in (127 mm)	23.9 Lb (10.9 kg)
4 inch (100 mm)	4.724 in (120 mm)	15.1 in (384 mm)	6.19 in (157 mm)	35.2 Lb (16.0 kg)

Add 11 lb (5 KG) for remote electronics

**Dimensional Outline: Remote Electronics Option**

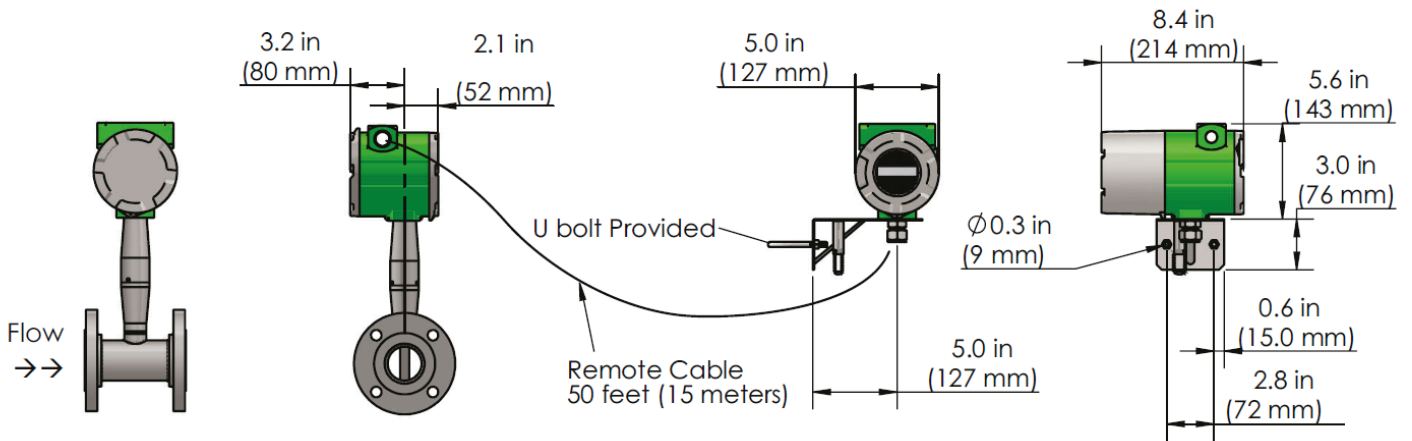

## Model Number Information - Pro-V™ Model M22 Inline Mass Vortex Flowmeter

### Parent Number Code

**M22** Inline Vortex Flowmeter

### Feature 1: Multivariable Options

**V** Volumetric Flowmeter for liquid, gas, and steam  
**VT** Velocity and Temperature Sensors  
**VTP** Velocity, Temperature, and Pressure Sensors  
**VTEP** Velocity, Temperature, and External 4-20mA Input (T or P)  
**VETEP** Velocity, External RTD Temperature Input, External 4-20mA Input (T or P)  
**VT-EM** Energy Output Options  
**VTP-EM** Energy Options with Pressure Sensor  
**VTEP-EM** Velocity, Temperature, External 4-20mA Input (T or P)  
**VETEP-EM** Velocity, External RTD Temperature Input, External 4-20mA Input (T or P)

### Feature 2: Flow Body (M22)

**04** ½-inch Nominal Bore (15mm)  
**06** ¾-inch Nominal Bore (20mm)  
**08** 1-inch Nominal Bore (25mm)  
**12** 1.5-inch Nominal Bore (40mm)  
**16** 2-inch Nominal Bore (50mm)  
**24** 3-inch Nominal Bore (80mm)  
**32** 4-inch Nominal Bore (100mm)  
**48** 6-inch Nominal Bore (150mm)  
**64** 8-inch Nominal Bore (200mm)  
**80** 10-inch Nominal Bore (250mm)  
**96** 12-inch Nominal Bore (300mm)

### Feature 3: Meter Body Material

**C** Carbon Steel (1.5" and up)  
**S** 316 Stainless Steel  
**H** Hastelloy

### Feature 4: Process Connection

<b>150</b>	ANSI 150# Flange	<b>16</b>	PN 16	<b>J10</b>	JIS 10K
<b>300</b>	ANSI 300# Flange	<b>40</b>	PN 40	<b>J20</b>	JIS 20K
<b>600</b>	ANSI 600# Flange	<b>63</b>	PN 63	<b>J30</b>	JIS 30K
<b>W</b>	Wafer ANSI 600#				

### Feature 5: Electronics Enclosure

**L** NEMA 4x IP66 Enclosure  
**R()** Remote Electronics NEMA 4X IP66 Enclosure, Specify cable length in parentheses, Standard 50ft

### Feature 6: Display Options

**DD** Digital Display and Programming Buttons

### Feature 7: Input Power

**DCL** 12-36 VDC, 25mA, 1W max. – required on loop powered meters, 1AHL only  
**DCH** 12-36 VDC, 300mA, 9W max. – use with 1AH, 1AM, 1AB, 3AH, 3AM, 3AB  
**DCHPOE** 12-28 VDC or Power Over Ethernet, 5W max. – required on 1AMIP, 1ABIP, 3AMIP, 3ABIP  
**AC** 100-240 VAC, 50/60 Hz line power, 5W max. – use with 1AH, 1AM, 1AB, 3AH, 3AM, 3AB

### Feature 8: Output

**1AHL** Loop powered option – one analog output (4-20mA), one scaled frequency, one pulse, HART, DCL input power only  
**1AH** One analog output (4-20mA), one alarm, one pulse, HART Communication Protocol, DCH or AC option only \*  
**1AM** One analog output (4-20mA), one alarm, one pulse, MODBUS RTU Communication Protocol, DCH or AC option only \*  
**1AMIP** One analog output (4-20mA), one alarm, one pulse, MODBUS TCP/IP Communication Protocol, DCHPOE option only \*  
**1AB** One analog output (4-20mA), one alarm, one pulse, BACnet MS/TP Communication Protocol, DCH or AC option only \*  
**1ABIP** One analog output (4-20mA), one alarm, one pulse, BACnet/IP Communication Protocol, DCHPOE option only \*  
**3AH** Three analog outputs (4-20mA), three alarms, one pulse, HART, VT or VTP option only, DCH or AC option only \*  
**3AM** Three analog outputs (4-20mA), three alarms, one pulse, MODBUS RTU, VT or VTP option only, DCH or AC option only \*  
**3AMIP** Three analog outputs (4-20mA), three alarms, one pulse, MODBUS TCP/IP, VT or VTP option only, DCHPOE option only \*  
**3AB** Three analog outputs (4-20mA), three alarms, one pulse, BACnet MS/TP, VT or VTP option only, DCH or AC option only \*  
**3ABIP** Three analog outputs (4-20mA), three alarms, one pulse, BACnet/IP, VT or VTP option only, DCHPOE option only \* \*Includes scaled frequency output

### Feature 9: Temperature Options

**ST** Standard Temperature – Process temperature -330° to 500° F (-200° to 260° C)      **HT** High Temperature – Process temperature up to 750° F (400° C)

### Feature 10: Pressure Options

<b>P0</b>	No Pressure Sensor	<b>P4</b>	Maximum 500 psia (34 bara), Proof 1000 psia (64 bara)
<b>P1</b>	Maximum 30 psia (2 bara), Proof 60 psia (4 bara)	<b>P5</b>	Maximum 1500 psia (100 bara), Proof 2500 psia (175 bara)
<b>P2</b>	Maximum 100 psia (7 bara), Proof 200 psia (14 bara)	<b>P6</b>	Maximum 2500 psia (172 bara), Proof 5000 psia (344 bara)
<b>P3</b>	Maximum 300 psia (20 bara), Proof 600 psia (41 bara)	<b>P7</b>	Maximum 1000 psia (69 bara), Proof 2000 psia (138 bara)

